

## BT350

**Suits 50mm Tow Ball**  
**Max. 3 500 kg ATM**

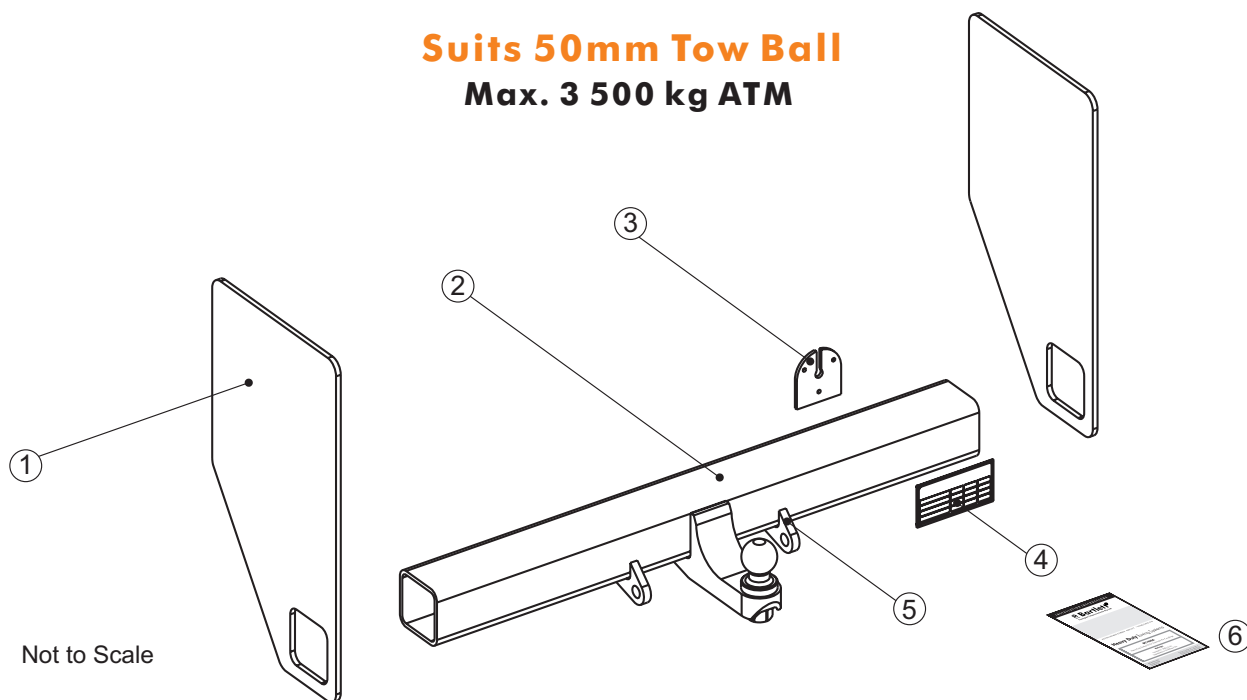

Item	Description	Qty. P/kit
1	Side Plates	2
2	Crossmember Assembly (inc. Item 5)	1
3	7 Pin Base Mount Plate	1
4	Rating Plate & Studs	1 Set
5	AS 4177 Safety Chain Attachment Lugs	2
6	Detailed Instruction Booklet	1

### For Towing Light Trailers

Rating:

Max: 3500 ATM\*

\* 3500 kg ATM when towing vehicle /5000 kg GVM.  
 Rating reduces as GVM exceeds 5000 kg.  
 per AS4177 by D -Value of ball 20.02 kN

Shipping Mass: 44kg

Not to Scale

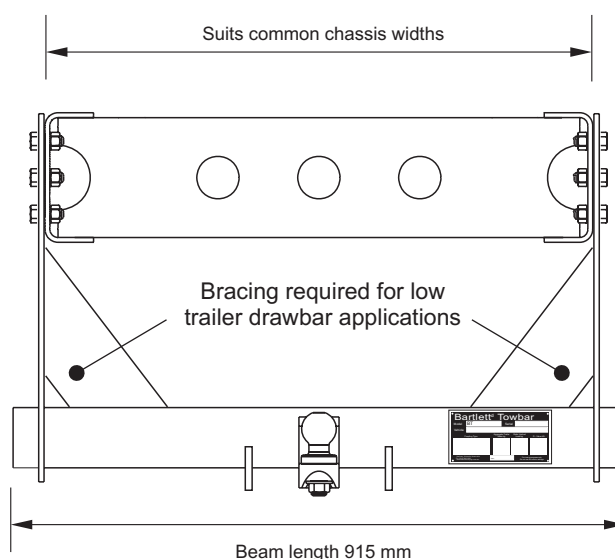
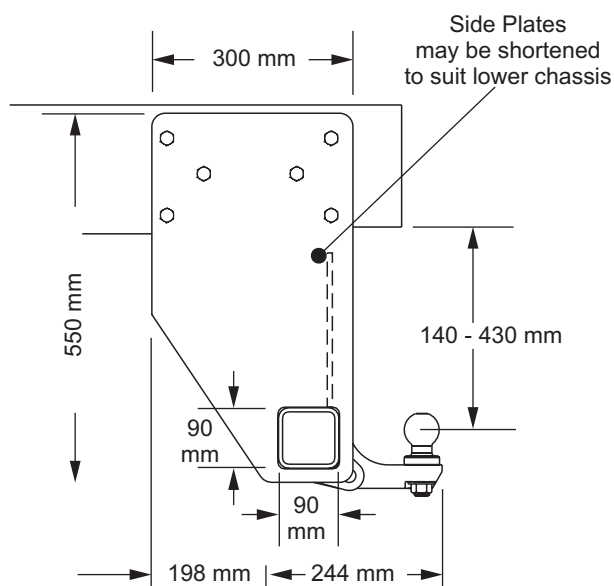

\* 50 mm Ball, sideplate braces sideplate bolts and holes not included - Shown for illustration only

\*\*BTI reserves the right to alter specifications without notice.